

## SkyLine PremiumS Natural Gas Combi Oven 6GN2/1, Green Version

ITEM # \_\_\_\_\_

MODEL # \_\_\_\_\_

NAME # \_\_\_\_\_

SIS # \_\_\_\_\_

AIA # \_\_\_\_\_

**229771 (ECOG62T3G1)**

SkyLine PremiumS combi boiler oven with touch screen control, 6x2/1GN, gas, 3 cooking modes (automatic, recipe program, manual), automatic cleaning, boiler in AISI 316, Green Version with 3-glass door

### Short Form Specification

#### Item No.

Combi oven with high resolution full touch screen interface, multilanguage

- Built-in steam generator (in s/s 316L) with real humidity control based upon Lambda Sensor
- OptiFlow air distribution system to achieve maximum performance with 7 fan speed levels
- SkyClean: Automatic and built-in self cleaning system with integrated descale of the steam generator. 5 automatic cycles (soft, medium, strong, extra strong, rinse-only) and green functions to save energy, water, detergent and rinse aid
- Cooking modes: Automatic (9 food families with 100+ different pre-installed variants); Programs (a maximum of 1000 recipes can be stored and organized in 16 different categories); Manual (steam, combi and convection cycles); Specialistic Cycles (regeneration, Low Temperature Cooking, proving, EcoDelta, Sous-Vide, Static-Combi, Pasteurization of pasta, dehydration, Food Safe Control and Advanced Food Safe Control)
- Special functions: MultiTimer cooking, Plan-n-Save to cut running costs, Make-it-Mine to customize interface, SkyHub to customize homepage, agenda MyPlanner, SkyDuo connection to SkyLine ChillerS, automatic backup mode to avoid downtime
- USB port to download HACCP data, programs and settings. Connectivity ready
- 6-point multi sensor core temperature probe
- Triple-glass door with double LED lights line
- Stainless steel construction throughout
- Supplied with n.1 tray rack 2/1 GN, 67 mm pitch.

### Main Features

- High resolution full touch screen interface (translated in more than 30 languages) - color-blind friendly panel.
- Built-in steam generator for highly precise humidity and temperature control according to the chosen settings.
- Real humidity control based upon Lambda Sensor to automatically recognize quantity and size of food for consistent quality results.
- Dry, hot convection cycle (25 °C - 300 °C): ideal for low humidity cooking.
- Combination cycle (25 °C - 300 °C): combining convected heat and steam to obtain humidity controlled cooking environment, accelerating the cooking process and reducing weight loss.
- Low temperature Steam cycle (25 °C - 99 °C): ideal for sous-vide, re-thermalization and delicate cooking. Steam cycle (100 °C): seafood and vegetables. High temperature steam (25 °C - 130 °C).
- Automatic mode including 9 food families (meat, poultry, fish, vegetables, pasta/rice, eggs, savory and sweet bakery, bread, dessert) with 100+ different pre-installed variants. Through Automatic Sensing Phase the oven optimizes the cooking process according to size, quantity and type of food loaded to achieve the selected cooking result. Real time overview of the cooking parameters. Possibility to personalize and save up to 70 variants per family.
- Cycles+: - Regeneration (ideal for banqueting on plate or rethermalizing on tray), - Low Temperature Cooking (to minimize weight loss and maximize food quality) Patented US7750272B2 and related family, - Proving cycle, - EcoDelta cooking, cooking with food probe maintaining preset temperature difference between the core of the food and the cooking chamber, - Sous-vide cooking, - Static Combi (to reproduce traditional cooking from static oven), - Pasteurization of pasta, - Dehydration cycles (ideal for drying fruits, vegetables, meats, seafood), - Food Safe Control (to automatically monitor safety of cooking process in compliance with HACCP hygienic standards) Patented US6818865B2 and related family, - Advanced Food Safe Control (to drive the cooking with pasteurization factor).
- Programs mode: a maximum of 1000 recipes can be stored in the oven's memory, to recreate the exact same recipe at any time. The recipes can be group in 16 different categories to better organize the menu. 16-step cooking programs also available.
- MultiTimer function to manage up to 20 different cooking cycles at the same time, improving flexibility and ensuring excellent cooking results. Can be saved up to 200 MultiTimer programs.
- Fan with 7 speed levels from 300 to 1500 RPM and reverse rotation for optimal evenness. Fan stops in less than 5 seconds when door is opened.
- 6-point multi sensor core temperature probe for maximum precision and food safety.
- Pictures upload for full customization of cooking

**APPROVAL:** \_\_\_\_\_

cycles.

- Automatic fast cool down and pre-heat function.
- Different chemical options available: solid (phosphate-free), liquid (requires optional accessory).
- Make-it-mine feature to allow full personalization or locking of the user interface.
- SkyHub lets the user group the favorite functions in the homepage for immediate access.
- MyPlanner works as an agenda where the user can plan the daily work and receive personalized alerts for each task.
- GreaseOut: predisposed for integrated grease drain and collection for safer operation (dedicated base as optional accessory).
- USB port to download HACCP data, share cooking programs and configurations. USB port also allows to plug-in sous-vide probe (optional accessory).
- Connectivity ready for real time access to connected appliances from remote and HACCP monitoring (requires optional accessory).
- Trainings and guidances supporting materials easily accessible by scanning QR-Code with any mobile device.
- Back-up mode with self-diagnosis is automatically activated if a failure occurs to avoid downtime.
- Automatic consumption visualization at the end of the cycle.
- [NOT TRANSLATED]
- [NOT TRANSLATED]
- [NOT TRANSLATED]

### Construction

- Triple thermo-glazed door with 2 hinged inside panels for easy cleaning and double LED lights line.
- Seamless hygienic internal chamber with all rounded corners for easy cleaning.
- 304 AISI stainless steel construction throughout.
- Front access to control board for easy service.
- Integrated spray gun with automatic retracting system for fast rinsing.
- IPX 5 spray water protection certification for easy cleaning.
- Supplied with n.1 tray rack 2/1 GN, 67 mm pitch.

### Sustainability

- Human centered design with 4-star certification for ergonomics and usability.
- Wing-shaped handle with ergonomic design and hands-free opening with the elbow, making managing trays simpler (Registered Design at EPO).
- Reduced power function for customized slow cooking cycles.
- SkyClean: Automatic and built-in self cleaning system with integrated descale of the steam generator. 5 automatic cycles (soft, medium, strong, extra strong, rinse-only) and green functions to save energy, water, detergent and rinse aid. Also programmable with delayed start.
- Plan-n-Save function organizes the cooking sequence of the chosen cycles optimizing the work in the kitchen from a time and energy efficiency point of view.
- With SkyDuo the Oven and the Blast Chiller are connected to each other and communicate in order to guide the user through the cook&chill process optimizing

time and efficiency (requires optional accessory).

- Zero Waste provides chefs with useful tips for minimizing food waste.  
Zero Waste is a library of Automatic recipes that aims to: give a second life to raw food close to expiration date (e.g.: from milk to yogurt)  
obtain genuine and tasty dishes from overripe fruit/vegetables (usually considered not appropriate for sale) promote the use of typically discarded food items (e.g.: carrot peels).
- Energy Star 2.0 certified product.

### Optional Accessories

- |   |            |                          |
|---|------------|--------------------------|
| • Water softener with cartridge and flow meter (high steam usage)                                       | PNC 920003 | <input type="checkbox"/> |
| • Water softener with salt for ovens with automatic regeneration of resin                               | PNC 921305 | <input type="checkbox"/> |
| • Wheel kit for 6 & 10 GN 1/1 and 2/1 GN oven base (not for the disassembled one)                       | PNC 922003 | <input type="checkbox"/> |
| • Pair of AISI 304 stainless steel grids, GN 1/1  | PNC 922017 | <input type="checkbox"/> |
| • Pair of grids for whole chicken (8 per grid - 1,2kg each), GN 1/1                                     | PNC 922036 | <input type="checkbox"/> |
| • AISI 304 stainless steel grid, GN 1/1   | PNC 922062 | <input type="checkbox"/> |
| • AISI 304 stainless steel grid, GN 2/1   | PNC 922076 | <input type="checkbox"/> |
| • External side spray unit (needs to be mounted outside and includes support to be mounted on the oven) | PNC 922171 | <input type="checkbox"/> |
| • Pair of AISI 304 stainless steel grids, GN 2/1  | PNC 922175 | <input type="checkbox"/> |
| • Baking tray for 5 baguettes in perforated aluminum with silicon coating, 400x600x38mm                 | PNC 922189 | <input type="checkbox"/> |
| • Baking tray with 4 edges in perforated aluminum, 400x600x20mm   | PNC 922190 | <input type="checkbox"/> |
| • Baking tray with 4 edges in aluminum, 400x600x20mm  | PNC 922191 | <input type="checkbox"/> |
| • Pair of frying baskets  | PNC 922239 | <input type="checkbox"/> |
| • AISI 304 stainless steel bakery/pastry grid 400x600mm   | PNC 922264 | <input type="checkbox"/> |
| • Double-step door opening kit  | PNC 922265 | <input type="checkbox"/> |
| • Grid for whole chicken (8 per grid - 1,2kg each), GN 1/1  | PNC 922266 | <input type="checkbox"/> |
| • USB probe for sous-vide cooking   | PNC 922281 | <input type="checkbox"/> |
| • Kit universal skewer rack and 6 short skewers for Lengthwise and Crosswise ovens                      | PNC 922325 | <input type="checkbox"/> |
| • Universal skewer rack   | PNC 922326 | <input type="checkbox"/> |
| • 6 short skewers   | PNC 922328 | <input type="checkbox"/> |
| • Smoker for lengthwise and crosswise oven (4 kinds of smoker wood chips are available on request)      | PNC 922338 | <input type="checkbox"/> |
| • Multipurpose hook   | PNC 922348 | <input type="checkbox"/> |
| • 4 flanged feet for 6 & 10 GN , 2", 100-130mm  | PNC 922351 | <input type="checkbox"/> |
| • Grease collection tray, GN 2/1, H=60 mm   | PNC 922357 | <input type="checkbox"/> |
| • Grid for whole duck (8 per grid - 1,8kg each), GN 1/1   | PNC 922362 | <input type="checkbox"/> |
| • Tray support for 6 & 10 GN 2/1 disassembled open base   | PNC 922384 | <input type="checkbox"/> |
| • Wall mounted detergent tank holder  | PNC 922386 | <input type="checkbox"/> |

• - NOT TRANSLATED -	PNC 922390	<input type="checkbox"/>	• Probe holder for liquids	PNC 922714	<input type="checkbox"/>
• Slide-in rack with handle for 6 & 10 GN 2/1 oven	PNC 922605	<input type="checkbox"/>	• Exhaust hood with fan for 6 & 10 GN 2/1 GN ovens	PNC 922729	<input type="checkbox"/>
• Tray rack with wheels, 5 GN 2/1, 80mm pitch	PNC 922611	<input type="checkbox"/>	• Exhaust hood with fan for stacking 6+6 or 6+10 GN 2/1 ovens	PNC 922731	<input type="checkbox"/>
• Open base with tray support for 6 & 10 GN 2/1 oven	PNC 922613	<input type="checkbox"/>	• Exhaust hood without fan for 6&10x2/1 GN oven	PNC 922734	<input type="checkbox"/>
• Cupboard base with tray support for 6 & 10 GN 2/1 oven	PNC 922616	<input type="checkbox"/>	• Exhaust hood without fan for stacking 6+6 or 6+10 GN 2/1 ovens	PNC 922736	<input type="checkbox"/>
• Hot cupboard base with tray support for 6 & 10 GN 2/1 oven holding 5xGN 2/1 trays	PNC 922617	<input type="checkbox"/>	• 4 high adjustable feet for 6 & 10 GN ovens, 230-290mm	PNC 922745	<input type="checkbox"/>
• External connection kit for detergent and rinse aid	PNC 922618	<input type="checkbox"/>	• Tray for traditional static cooking, H=100mm	PNC 922746	<input type="checkbox"/>
• Stacking kit for gas 6X2/1 GN oven on gas 6&10X2/1 GN oven	PNC 922624	<input type="checkbox"/>	• Double-face griddle, one side ribbed and one side smooth, 400x600mm	PNC 922747	<input type="checkbox"/>
• Stacking kit for gas 6 GN 2/1 oven placed on gas 10 GN 2/1 oven	PNC 922625	<input type="checkbox"/>	• - NOT TRANSLATED -	PNC 922752	<input type="checkbox"/>
• Trolley for slide-in rack for 6 & 10 GN 2/1 oven and blast chiller freezer	PNC 922627	<input type="checkbox"/>	• - NOT TRANSLATED -	PNC 922773	<input type="checkbox"/>
• Trolley for mobile rack for 2 stacked 6 GN 2/1 ovens on riser	PNC 922629	<input type="checkbox"/>	• - NOT TRANSLATED -	PNC 922776	<input type="checkbox"/>
• Trolley for mobile rack for 6 GN 2/1 on 6 or 10 GN 2/1 ovens	PNC 922631	<input type="checkbox"/>	• Non-stick universal pan, GN 1/1, H=20mm	PNC 925000	<input type="checkbox"/>
• Riser on feet for stacked 2x6 GN 2/1 ovens	PNC 922633	<input type="checkbox"/>	• Non-stick universal pan, GN 1/1, H=40mm	PNC 925001	<input type="checkbox"/>
• Riser on wheels for stacked 2x6 GN 2/1 ovens, height 250mm	PNC 922634	<input type="checkbox"/>	• Non-stick universal pan, GN 1/1, H=60mm	PNC 925002	<input type="checkbox"/>
• Stainless steel drain kit for 6 & 10 GN oven, dia=50mm	PNC 922636	<input type="checkbox"/>	• Double-face griddle, one side ribbed and one side smooth, GN 1/1	PNC 925003	<input type="checkbox"/>
• Plastic drain kit for 6 & 10 GN oven, dia=50mm	PNC 922637	<input type="checkbox"/>	• Aluminum grill, GN 1/1	PNC 925004	<input type="checkbox"/>
• Trolley with 2 tanks for grease collection	PNC 922638	<input type="checkbox"/>	• Frying pan for 8 eggs, pancakes, hamburgers, GN 1/1	PNC 925005	<input type="checkbox"/>
• Grease collection kit for open base (2 tanks, open/close device and drain)	PNC 922639	<input type="checkbox"/>	• Flat baking tray with 2 edges, GN 1/1	PNC 925006	<input type="checkbox"/>
• Wall support for 6 GN 2/1 oven	PNC 922644	<input type="checkbox"/>	• Potato baker for 28 potatoes, GN 1/1	PNC 925008	<input type="checkbox"/>
• Dehydration tray, GN 1/1, H=20mm	PNC 922651	<input type="checkbox"/>	• Compatibility kit for installation on previous base GN 2/1	PNC 930218	<input type="checkbox"/>
• Flat dehydration tray, GN 1/1	PNC 922652	<input type="checkbox"/>			
• Open base for 6 & 10 GN 2/1 oven, disassembled	PNC 922654	<input type="checkbox"/>			
• Heat shield for 6 GN 2/1 oven	PNC 922665	<input type="checkbox"/>			
• Heat shield-stacked for ovens 6 GN 2/1 on 6 GN 2/1	PNC 922666	<input type="checkbox"/>			
• Heat shield-stacked for ovens 6 GN 2/1 on 10 GN 2/1	PNC 922667	<input type="checkbox"/>			
• Kit to convert from natural gas to LPG	PNC 922670	<input type="checkbox"/>			
• Kit to convert from LPG to natural gas	PNC 922671	<input type="checkbox"/>			
• Flue condenser for gas oven	PNC 922678	<input type="checkbox"/>			
• Fixed tray rack, 5 GN 2/1, 85mm pitch	PNC 922681	<input type="checkbox"/>			
• Kit to fix oven to the wall	PNC 922687	<input type="checkbox"/>			
• Tray support for 6 & 10 GN 2/1 open base	PNC 922692	<input type="checkbox"/>			
• 4 adjustable feet with black cover for 6 & 10 GN ovens, 100-115mm	PNC 922693	<input type="checkbox"/>			
• Detergent tank holder for open base	PNC 922699	<input type="checkbox"/>			
• Tray rack with wheels, 6 GN 2/1, 65mm pitch (included)	PNC 922700	<input type="checkbox"/>			
• - NOT TRANSLATED -	PNC 922706	<input type="checkbox"/>			
• Mesh grilling grid	PNC 922713	<input type="checkbox"/>			

Front

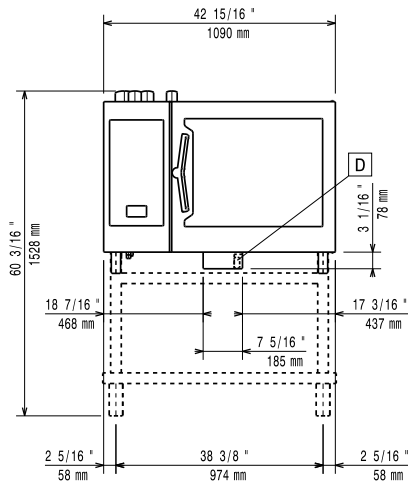

Side

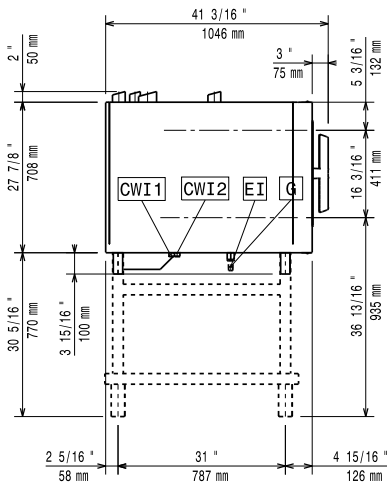

- CWI1 = Cold Water inlet 1
- CWI2 = Cold Water Inlet 2
- D = Drain
- DO = Overflow drain pipe
- EI = Electrical inlet (power)
- G = Gas connection

Top

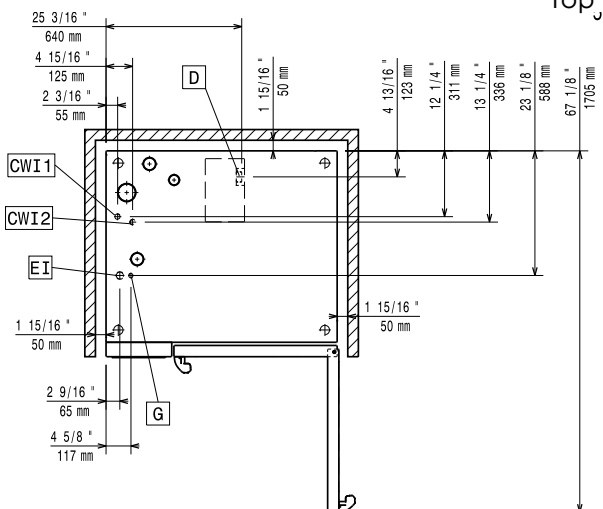

### Electric

<b>Supply voltage:</b>	229771 (ECOG62T3G1)	220-240 V/1 ph/50 Hz
<b>Electrical power, default:</b>		1.5 kW
<b>Electrical power max.:</b>		1.5 kW
<b>Circuit breaker required</b>		

### Gas

<b>Gas Power:</b>	32 kW
<b>Standard gas delivery:</b>	Natural Gas G20
<b>ISO 7/1 gas connection diameter:</b>	1/2" MNPT
<b>Total thermal load:</b>	109088 BTU (32 kW)

### Water:

<b>Water inlet "FCW" connection:</b>	3/4"
<b>Pressure, bar min/max:</b>	1-6 bar
<b>Drain "D":</b>	50mm
<b>Max inlet water supply temperature:</b>	30 °C
<b>Chlorides:</b>	<20 ppm
<b>Conductivity:</b>	>50 µS/cm
<b>Electrolux Professional</b> recommends the use of treated water, based on testing of specific water conditions. Please refer to user manual for detailed water quality information.	

### Installation:

<b>Clearance:</b>	Clearance: 5 cm rear and right hand sides.
<b>Suggested clearance for service access:</b>	50 cm left hand side.

### Capacity:

<b>GN:</b>	6 - 2/1 Gastronorm
<b>Max load capacity:</b>	60 kg

### Key Information:

<b>Door hinges:</b>	
<b>External dimensions, Width:</b>	1090 mm
<b>External dimensions, Depth:</b>	971 mm
<b>External dimensions, Height:</b>	808 mm
<b>Net weight:</b>	176 kg
<b>Shipping weight:</b>	199 kg
<b>Shipping volume:</b>	1.27 m <sup>3</sup>

### ISO Certificates

<b>ISO Standards:</b>	04
-----------------------	----